

## Foldable Hydraulic Mobile Floor Crane (PMC-Series)

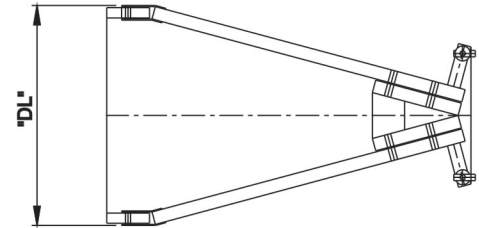
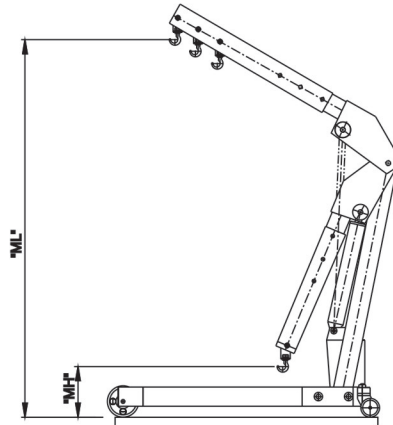

Model	Capacity	Stroke	Max. Lift 'ML'	Max. Dist betw. Legs 'DL'	Weight (appx)
	tons.	mm.	mm.	mm.	kgs.
PMC-1	1	2350	300	1025	95
PMC-2	2	2500	300	1150	125
PMC-3	3	2600	300	1150	135

### Features / Benefits :

- Heavy duty, rugged construction.
- Foldable legs for portability.
- Horizontal boom adjustable and lockable.
- Single acting, load return, hand pump operated.
- Cylinder honed to a surface finish of 0.4 microns.
- Hard chrome plated ram to resist scoring and corrosion.
- Front wheels are fixed and rear wheels are 360° movable for easy mobility.

**⚠ Crane is designed to lift the load and not to move lifted load.**